

HBPN064403 TYPE

SPECIALIZE IN HIGH CURRENT & HIGH
INDUCTANCE FOR SMD INDUCTORS

CHARACTERISTICS

1. TESTED AT 100 KHz, 0.1 VRMS
2. OPERATING TEMPERATURE RANGE :
-40°C TO +85°C
3. ELECTRICAL SPECIFICATIONS AT 25°C
4. IDC2; BASE ON TEMP. (AT=30°C)

ELECTRICAL SPECIFICATION

ITEM	SRF	DCR	IDC1	IDC2
HBPN064403	(MHz)	MAX.(Ω)	MAX.(A)	MAX.(A)
1R0M	130.0	0.05	2.90	2.90
1R5M	115.0	0.05	2.60	2.80
2R2M	90.0	0.07	2.30	2.40
3R3M	70.0	0.08	2.00	2.20
4R7M	50.0	0.09	1.50	1.50
6R8M	45.0	0.13	1.20	1.40
100M	35.0	0.16	1.10	1.10
150M	30.0	0.23	0.90	1.20
220M	20.0	0.37	0.70	0.80
330M	15.0	0.51	0.58	0.60
470M	14.0	0.64	0.50	0.50
680M	11.0	0.86	0.70	0.40
101M	9.0	1.27	0.31	0.30
151M	6.0	2.00	0.27	0.25
221M	5.5	3.11	0.22	0.20
331M	5.0	3.80	0.18	0.16
471M	4.0	5.06	0.16	0.15
681M	3.0	9.20	0.14	0.12
102M	2.0	13.80	0.10	0.07

CONSTRUCTION (m/m)

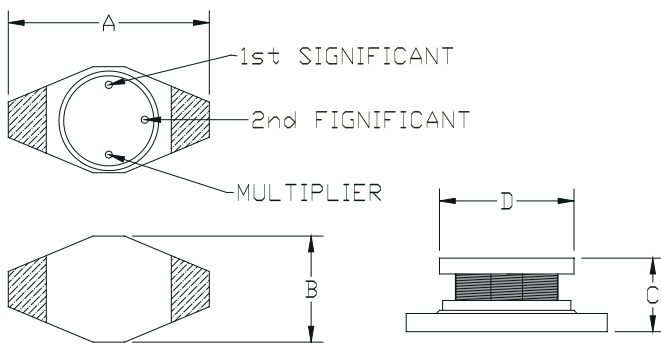

A: 6.6 MAX. B: 4.445 MAX.
C: 2.92 MAX.

COIL CODE

HBPN 06 44 03 150 M

TOLERANCE : ± 20%

INDUCTANCE : 15 μH

C DIM.

B DIM.

A DIM.

HBPN TYPE

* Hong can design any part to your requirements with different inductance.

* All parameters as this content presented are subject to final specifications both sides confirmed.